

Profile Data

Guide Ring BWR05

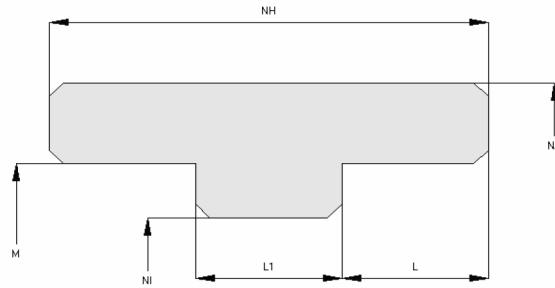

Function

Guiding elements are designed to prevent metal to metal contact between components of hydraulic systems e.g. piston and cylinder barrel or shaft and cylinder head.

Features

- ⇒ Normally cut at an angle for easy installation, but also available as non-split version.
- ⇒ For use in piston applications.
- ⇒ Integrated collar on inside diameter.
- ⇒ Low dynamic friction.
- ⇒ Low break-away forces after long standstills.

Application

mainly used at minor loads e.g. pneumatic applications

Installation

Snap-in installation.

Seal housing recommendation

Tolerances	[mm]	
NH	+ 0.2	
NL	+ 0.2	
∅ NA	H8	
∅ NI	h9	
Surface roughness	Rtmax [μ]	Ra [μ]
Bottom of groove	≤ 6.3	≤ 1.6
Face of groove	≤ 15	≤ 3
Sliding surface	Rtmax [μ]	Ra [μ]
PU, elastomeres	≤ 2.5	≤ 0.1-0.5
PTFE	≤ 2	≤ 0.05-0.3

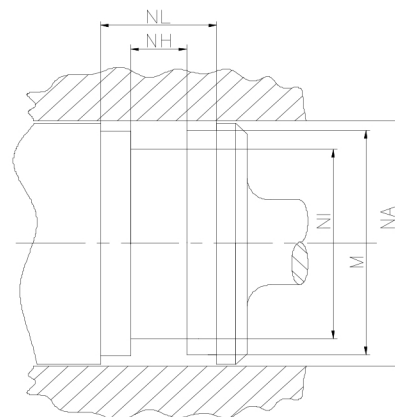

Sealco House, Maypole Fields Halesowen, West Midlands, UK, B63 2QB

T: (+44)1384 413058 E: sales@sealco.co.uk W: www.sealco.co.uk