

Profile Data

Guide Ring BWR08

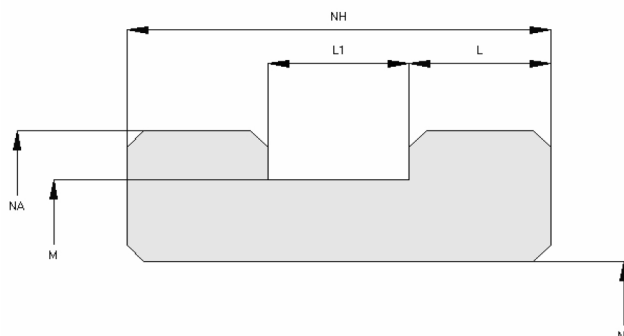

Function

Guiding elements are designed to prevent metal to metal contact between components of hydraulic systems e.g. piston and cylinder barrel or shaft and cylinder head.

Features

- ⇒ Normally cut at an angle for easy installation, but also available as non-split version.
- ⇒ For use in rod applications.
- ⇒ Integrated collar on outside diameter.
- ⇒ Design combines guiding and backing function.
- ⇒ Low dynamic friction.
- ⇒ Low break-away forces after long standstills.

Application

Reciprocating pistons and rods in hydraulic cylinders, plungers.

Installation

Snap-in installation.

Seal housing recommendation

Tolerances	[mm]	
∅ NA	H9	
∅ NI	h8	
∅ M	H9	
Surface roughness	Rtmax [μ]	Ra [μ]
Bottom of groove	≤ 6.3	≤ 1.6
Face of groove	≤ 15	≤ 3
Sliding surface	Rtmax [μ]	Ra [μ]
PU, elastomeres	≤ 2.5	≤ 0.1-0.5
PTFE	≤ 2	≤ 0.05-0.3

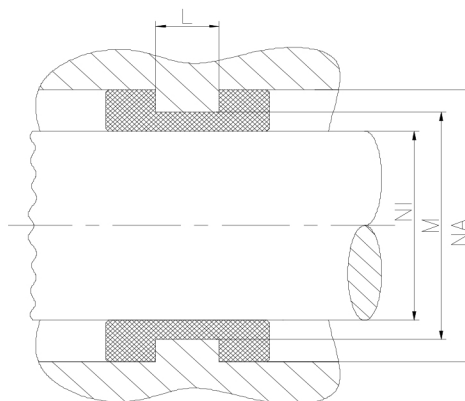

Sealco House, Maypole Fields Halesowen, West Midlands, UK, B63 2QB

T: (+44)1384 413058 E: sales@sealco.co.uk W: www.sealco.co.uk