

Profile Data Piston Seal PS03

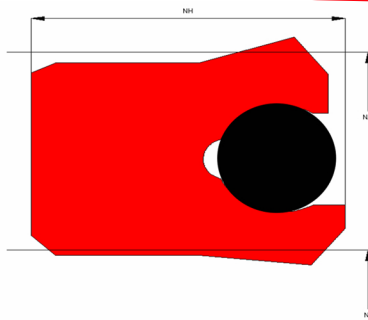

Function

Piston seals are designed to seal the pressurized hydraulic fluid against the atmosphere or between two pressurized spaces.

Features

- ⇒ Asymmetrical, single acting piston seal, designed with interference on the ID which provides a good static fit in the groove.
- ⇒ Dynamic sealing lip shorter than static lip to avoid drag pressure.
- ⇒ Increased preload due to an additional O-Ring
- ⇒ Excellent static and dynamic sealing performance.
- ⇒ Excellent performance in all pressure ranges.
- ⇒ Used for short, pulsating strokes.
- ⇒ No reverse leakage when changing direction.
- ⇒ Recommended for positioning or holding under pressure.

Application

Reciprocating pistons in hydraulic cylinders, plungers, push rods, fittings, etc.
Switching or clamping functions
Max. pressure 400 bar, max. speed 0.5 m/s.

Installation

Snap-in installation.

Seal housing recommendation

Tolerances	[mm]	
L < 10mm	+ 0.2	
L ≥ 10mm	+ 0.3	
∅ NA	H9	
∅ NI	h10	
Surface roughness	Rtmax [μ]	Ra [μ]
Bottom of groove	≤ 6.3	≤ 1.6
Face of groove	≤ 15	≤ 3
Sliding surface	Rtmax [μ]	Ra [μ]
PU, elastomer	≤ 2.5	≤ 0.1-0.5
PTFE	≤ 2	≤ 0.05-0.3

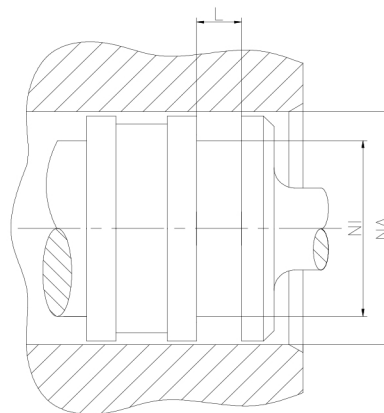

Sealco House, Maypole Fields Halesowen, West Midlands, UK, B63 2QB

T: (+44)1384 413058 E: sales@sealco.co.uk W: www.sealco.co.uk