

Profile Data

Rotary Seal RS19

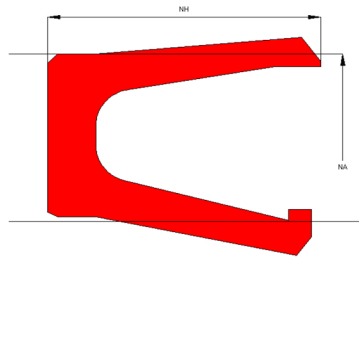

Function

Rod seals are designed to seal the pressurized hydraulic fluid against the atmosphere or between two pressurized spaces.

Features

- ⇒ Asymmetrical, single acting rod seal, designed with no interference on the static sealing diameter.
- ⇒ Preload effected through V-spring.
- ⇒ Dynamic sealing lip shorter than static lip to avoid drag pressure.
- ⇒ Excellent static and dynamic sealing performance.
- ⇒ Useable for short and long stroke lengths.
- ⇒ Low friction in dry running or poor lubrication conditions.
- ⇒ Negligible tendency to “stick-slip” effect, small break away loads.

Application

Reciprocating and swivelling rods in hydraulic cylinders, plungers.
Chemical and pharmaceutical industry, aggressive fluids and high temp.
Max. pressure 160 bar, max. speed 15 m/s.

Installation

Installation in open housing, snap-in installation possible in special designed housings.

Seal housing recommendation

Tolerances	[mm]	
L < 10mm	+ 0.2	
L ≥ 10mm	+ 0.3	
∅ NA	H9	
∅ NI	h10	
Surface roughness	Rtmax [μ]	Ra [μ]
Bottom of groove	≤ 6.3	≤ 1.6
Face of groove	≤ 15	≤ 3
Sliding surface	Rtmax [μ]	Ra [μ]
PU, elastomeres	≤ 2.5	≤ 0.1-0.5
PTFE	≤ 2	≤ 0.05-0.3

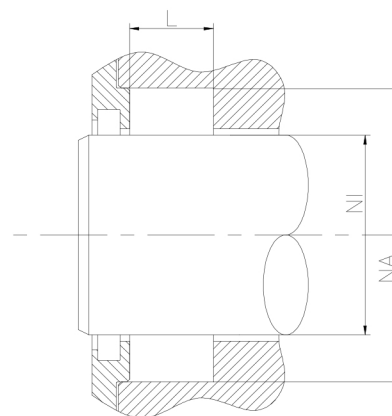

Sealco House, Maypole Fields Halesowen, West Midlands, UK, B63 2QB

T: (+44)1384 413058 E: sales@sealco.co.uk W: www.sealco.co.uk